

A 210mm

B 210mm

Automatic Rice-husk Carbonizer (ARC)

● Flow Chart

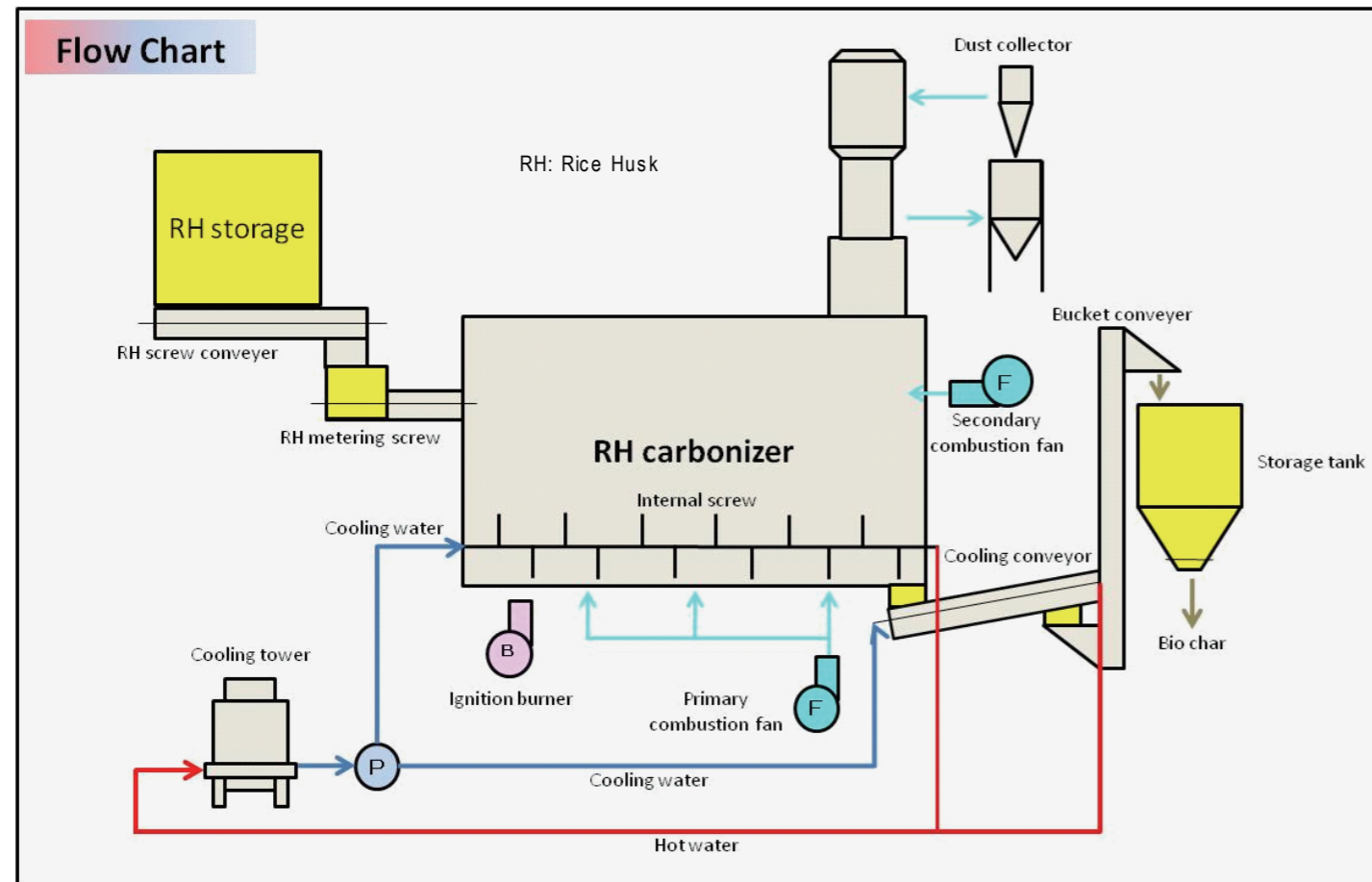

● Main specification

Type	LM-900
Performance	900kg/h (Rice husk)
Capacity	220kg/h (charcoal)
Size	12,000(W)×7,000(L)×8,000(H) mm
Dry weight	16t
Power	13kW
Cooling Water	50 l /min (※)
Option	Automatic bag-filling machine (baler)

(※) without recover

It is possible to recover the heat radiation.



⚠ Read carefully instruction manual before operation

KANSAI CORPORATION

Main Office and Laboratory
 1666 Minamikawasecho Hikone city, Shiga, Jaqan 522-0222
 TEL +81-749-25-1111 FAX +81-749-25-1115
 E-mail: info@kansai-sangyo.co.jp

<http://www.kansai-sangyo.co.jp>

- Will be changed without notice when necessary.
- Sometimes color of the photograph is differ from actual machine.
- Printed; October, 2013.



Automatic Rice-husk Carbonizer (ARC)



**We are Pioneer of the ARC
 in the World!!**

KANSAI CORPORATION